

Goedhart FC38S



Goedhart FC38D



Goedhart FC38L



Goedhart FC38

Standard air coolers

Cu/Al

R404A - Coolants



Goedhart FC38

The range GEA Goedhart FC38 standard ceiling mounted air coolers are standard air coolers for cooling and freezing applications (FC38S), working/preparation rooms and storage rooms for humidity sensitive products (FC38D) and for cold storage rooms with height limitation (FC38L).

The standard FC38 aircoolers are suitable for all known refrigerants and not corrosive coolants, with the exception of NH3.

Type description

FC38Si(dx) 6.2.40.7-230-E

FC38S = Ceiling mounted air coolers	2	= Number of fans
FC38D = Dual discharge air coolers		
FC38L = Extra low air cooler	40	= Fan diameter in cm
i = internally enhanced tubes	7	= Fin spacing
p = plain tubes		
(dx) = R404A	230	= 1x230V Fan tension
(G) = coolant	400	= 3x400V Fan tension
6 = number of tubes deep	E	= Electrical defrost
	H	= Hot gas defrost

General features

Coil block

- Tube distance : 38x33 mm versprongen
- Tubes : 12mm o.d copper tube
- : I= internally enhanced tubes for refrigerants (dx)
P= internally plain tubes for coolants(G) and refrigerants (dx)
- Fins : aluminium HT-fins
- Fin spacing : 4 mm : Suitable for applications with air temperatures above 0°C and with expected limited frost
: 7 mm : Suitable for applications with air temperatures below 0°C and expected frost
- A good thermal with the fins contact because the copper tubes are mechanically expanded into fully collared aluminium fins.
- The suction header is executed with a Schröder valve for testing applications
- All coil blocks for refrigerants are pressure tested to 40 bars. All coil blocks for coolants are pressure tested to 15 bars.
- FC38 aircoolers are supplied with a light overpressure charge.

General features

Casing

- Standard refrigerant connections are fixed on the left hand side of the unit when looking with the direction of the air flow.
- Construction suitable for mounting to the ceiling.
- The FC38 casing is made from galvanized sheet steel, with exception of:
 - FC38S drip tray is hinged and made from light aluminum.
 - FC38D has a fixed galvanized drip tray.
 - FC38L drip tray is hinged and made from light aluminum.
- The fans of the FC38D are mounted to the outside of the drip tray of the air cooler and are wired.
- Goedhart FC38SB and FC38L air cooler is executed with a short air conduction plate as standard.
- The casing has a corrosion resistant white epoxy spray finish (RAL 9003).
- Almost all fixing materials are made of stainless steel to prevent corrosion.
- A possible hot gas spiral or electric defrost elements will be fixed to the bottom side of the coil

Standard options

Optional extra's	FC38S	FC38D	FC38L
Draw through execution	•		
Insulated drip tray	•		
StSt casing	•	•	•
Goldlack fins (4 / 7 mm)	•	•	•
Almg fins (4 mm)	•	•	•

Options on request

Optional extra's	FC38S	FC38D	FC38L
Hot gas defrost	•		
Warm glycol defrost	•		
Fan heating	•		•
Splash plate	•		
StSt tubes	•	•	•

P.E.D.

All air coolers produced by Goedhart comply with the Pressure Equipment Directive 97/23/EC. PED certificates can be downloaded from www.goedhart.nl.

Guarantee

Goedhart gives in conformity with her general conditions of delivery the following guarantee period on the Goedhart FC38 air coolers:

- within a 12 month period of product use
- at the latest within 18 months after the time of delivery.

Sound data

The mean sound pressure (LpA @ 3m ± 2 dB (A)) each air cooler is a calculated indication value according to the EN13487 standard parallel pipe. Goedhart uses the fan manufacturer's sound power level (LwA) at the inlet side of the fan. Changes to or by the fan or the product, affect the sound, in these cases, consult the manufacturer for the new indication value. In critical sound requirements, we advise you to consult an expert.

Defrost systems

For room temperatures where ripe formation can be expected and where the coil can not be defrosted by the room air, electrical or hot gas defrost is necessary

Electrical defrost

On request FC38 can be provided with electrical defrost. FC38 is always delivered with heavy defrost. The heater elements are rated for 220/240 V and are 400/420 V with zero wire supply. The stainless steel heater elements are fitted in the coil block in inner tubes which form a highly conductive medium between the heaters and the fins. In the drip-tray, the heater elements are fitted to the bottom side of the underside of the aluminum inner tray. The heater elements in the coil block are removable from the header side of the unit, whilst the tray heater elements can be removed once the outer tray has been taken off.

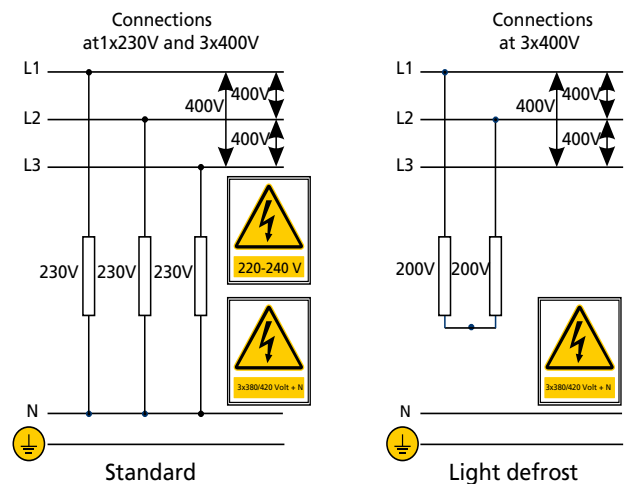

Hot gas defrost

The coil block is suited for hot gas defrost (hot gas supply through the suction header). The drip tray can be provided with a copper hot gas spiral, which is enclosed in special aluminum profiles, which are rigidly secured to underside of the aluminum inner tray.

Mounting & Maintenance

FC38 is delivered in a wooden crate. FC38S will be delivered with the separate drip-tray. When crated, FC38 can be handled by crane or fork-lift truck, which makes it very easy to mount. The drip-tray of the FC38S is delivered separately. For maintenance and instructions see our manual delivered on order or can be downloaded from our web site www.goedhart.nl.



Fans

GEA Goedhart FC38 aircoolers are executed with Ziehl Abegg: (We reserve the right to alter the manufacturer).

The fans are suitable for operation in air temperatures between -25°C to +40°C. When the air temperature is lower than -25°C, special fans are needed. These special fans have a longer delivery time. The protection class is IP54. The fans are not available with stainless steel protection guards

At all GEA Goedhart FC38 air cooler types (FC38S, FC38D and FC38L) the fans are mounted to the outside of aircooler!

The technical data in the table are the same as on the motor name plates and is valid for an air temperature of +20 °C. Also the data are given for working in an air temperature of 0 °C and -20 °C.

1x230V-50Hz

The standard connection tension for the Ziehl Abegg fans is 230V-50Hz-1 phase for the fan diameters Ø250, Ø300, Ø350, Ø400, Ø450 and Ø500. The fan motors of the Ø250, Ø300 and Ø350 mm fans are standard equipped with internally connected thermo contacts. Ø400, Ø450 and Ø500 mm fans are equipped with thermal contacts lead outside.

3x400V-50Hz

The EBMpapst Ø400, Ø450 and Ø500 fan is on request available in 230/400V-50Hz-3 phase. The fan is executed with a thermal contact lead to the outside.

Connecting thermal contacts

If the thermal contacts are not connected the warranty on the fans expires.

Frequency controlling

When a frequency converter is applied, always an All pole sinus filter should be used!

Fan type	Values at 1x230V-50Hz					Sound power indication ach fan LwA (+/-2dB(A))	Wiring diagram
	Speed	Input	+20°C	0°C	-20°C		
			FLC	FLC	FLC		
rpm	[W]	[A]	[A]	[A]	[dBA]		
4 pole fans (1500 rpm nominal)							
FN025	1370	50	0,24	0,26	0,28	62	177X
FN030	1290	90	0,39	0,43	0,45	65	177X
FN035	1260	170	0,75	0,82	0,87	75	177X
FN040	1370	240	1,10	1,20	1,28	76	104XB
FN045	1320	550	2,50	2,73	2,90	80	104XB
FN050	1230	750	3,30	3,60	3,83	81,5	104XB
6 pole fans (1000 tpm nominal)							
FN040	950	130	0,58	0,63	0,67	68	104XB
FN045	910	190	0,90	0,98	1,04	68,5	104XB
FN050	910	300	1,30	1,42	1,51	71,5	104XB

Fan type	Values at 3x400V(Δ)-50Hz					Sound power indication ach fan LwA (+/-2dB(A))	Wiring diagram
	Speed	Input	+20°C	0°C	-20°C		
			FLC	FLC	FLC		
rpm	[W]	[A]	[A]	[A]	[dBA]		
4 pole fans (1500 rpm nominal)							
FN040	1370	230	0,40	0,44	0,46	76	108XB
FN045	1250	350	0,64	0,69	0,74	78	108XB
FN050	1300	770	1,70	1,85	1,97	81	108XB

Wiring diagram

Ziehl Abegg 1x230V-50Hz (177X)

U2= blue or grey
Z2= black
TB=braun

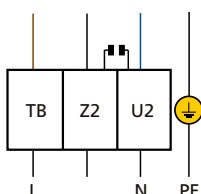

Ziehl Abegg 3x400V (Δ)-50Hz (108XB)

U1 =braun
V1 =blue
W1=black
U2 =red
V2 =grey
W2=orange
TB =white

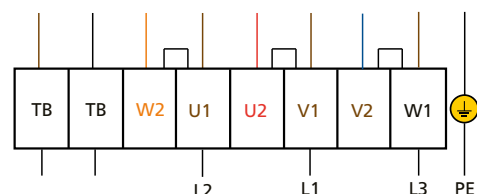

Ziehl Abegg 1x230V-50Hz (104XB)

U1 =braun
U2 =blue
Z1 =black
Z2 =orange
TB =white

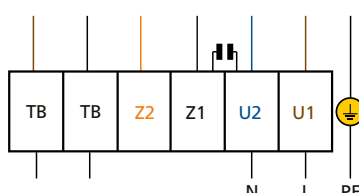

Ziehl Abegg 3x400V (Y)-50Hz (108XB)

U1 =braun
V1 =blue
W1=black
U2 =red
V2 =grey
W2=orange
TB =white

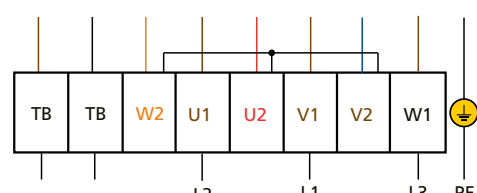

Goedhart FC38Sp(dx) - R404A

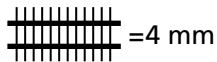

Type	Fan diameter	1x230V-50Hz-4 pole (1500 min ⁻¹ nom.)					Surface	Connections		Weight	Internal volume
		SC1	SC2	SC3	Air volume	LpA @ 3 m (+/- 2 dB(A))*		I	K		
FC38S	mm	DT1 = 10K Air on =10°C 0 / +10	DT1 = 8K Air on =0°C -8 / 0	DT1 = 7K Air on =-18°C -25 / -18	m ³ /h	dB(A)	m ²	mm	mm	kg	dm ³
4.1.25.4	1x250	1,8	1,2		632	40,8	7	12	12	26	2
4.1.30.4	1x300	3,4	2,3		1124	43,7	11	12	12	34	3
6.1.30.4	1x300	3,6	2,4		980	43,7	16	12	22	39	4
6.1.35.4	1x350	6,5	4,5		1794	53,5	25	12	22	51	6
6.1.40.4	1x400	9,2	6,3		2531	54,4	34	12	22	63	8
6.1.45.4	1x450	14,5	9,9		4565	58,3	45	12	22	75	10
4.2.30.4	2x300	6,7	4,6		2241	46,5	22	12	22	50	5
6.2.30.4	2x300	7,7	5,3		1952	46,5	32	12	22	61	7
6.2.35.4	2x350	13,0	8,9		3578	56,3	50	12	22	82	11
6.2.40.4	2x400	18,6	12,6		5051	57,1	68	16	28	103	15
6.2.45.4	2x450	29,8	19,9		9115	61,0	90	16	28	122	19
6.2.50.4	2x500	37,3	24,9		11131	62,3	112	16	35	204	24
6.3.30.4	3x300	11,4	7,9		2923	48,1	49	12	22	81	11
6.3.35.4	3x350	19,8	13,4		5363	57,8	75	16	28	112	16
6.3.40.4	3x400	27,2	18,1		7570	58,6	102	16	35	142	22
6.3.45.4	3x450	45,2	30,2		13665	62,5	134	16	35	174	28
6.3.50.4	3x500	55,8	37,2		16686	63,8	168	22	42	291	35
6.4.30.4	4x300	15,4	10,4		3895	49,2	65	16	28	104	14
6.4.35.4	4x350	26,9	18,1		7148	58,9	99	16	35	143	21
6.4.40.4	4x400	37,7	25,3		10089	59,7	136	16	35	183	29
6.4.45.4	4x450	60,7	40,5		18214	63,5	179	16	42	222	38
6.4.50.4	4x500	75,5	50,0		22242	64,7	224	22	42	376	47
6.5.45.4	5x450	76,9	50,9		22764	64,2	223	16	42	267	47
6.6.45.4	6x450	91,7	61,2		27314	64,7	268	22	42	322	56

* = Sound pressure indication (LpA) at 3 m distance each air cooler (+/- 2 dB(A)) , free field conditions, according EN13487

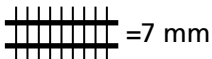

Type	Fan diameter	1x230V-50Hz-4 pole (1500 min ⁻¹ nom.)					Surface	Connections		Weight	Internal volume
		SC1	SC2	SC3	Air volume	LpA @ 3 m (+/- 2 dB(A))*		I	K		
FC38S	mm	DT1 = 10K Air on =10°C 0 / +10	DT1 = 8K Air on =0°C -8 / 0	DT1 = 7K Air on =-18°C -25 / -18	m ³ /h	dB(A)	m ²	mm	mm	kg	dm ³
4.1.25.7	1x250	1,3	0,8	0,6	720	40,8	4	12	12	25	2
4.1.30.7	1x300	2,7	1,8	1,3	1309	43,7	7	12	12	32	3
6.1.30.7	1x300	3,2	2,2	1,5	1194	43,7	10	12	12	36	4
6.1.35.7	1x350	5,6	3,8	2,7	2103	53,5	15	12	22	46	6
6.1.40.7	1x400	7,8	5,2	3,8	2964	54,4	21	12	22	57	8
6.1.45.7	1x450	12,0	8,1	5,8	5217	58,3	27	12	22	67	10
4.2.30.7	2x300	5,3	3,6	2,6	2612	46,5	13	12	22	47	5
6.2.30.7	2x300	6,6	4,4	3,3	2381	46,5	19	12	22	56	7
6.2.35.7	2x350	11,1	7,5	5,4	4199	56,3	30	12	22	74	11
6.2.40.7	2x400	15,5	10,4	7,6	5918	57,1	41	16	22	92	15
6.2.45.7	2x450	24,2	16,1	11,6	10423	61,0	54	16	28	109	19
6.2.50.7	2x500	30,0	19,9	14,4	12823	62,3	67	16	28	186	24
6.3.30.7	3x300	10,0	6,8	4,9	3568	48,1	29	12	22	74	11
6.3.35.7	3x350	16,8	11,3	8,1	6295	57,8	45	16	22	100	16
6.3.40.7	3x400	23,1	15,4	10,8	8873	58,6	61	16	28	126	22
6.3.45.7	3x450	36,6	24,1	17,4	15628	62,5	80	16	35	152	28
6.3.50.7	3x500	45,4	29,9	21,5	19226	63,8	101	16	35	263	35
6.4.30.7	4x300	13,4	9,1	6,5	4754	49,2	39	12	22	93	14
6.4.35.7	4x350	22,5	15,1	10,9	8389	58,9	60	16	28	127	21
6.4.40.7	4x400	31,3	20,9	15,2	11828	59,7	82	16	35	161	29
6.4.45.7	4x450	49,1	32,3	23,1	20834	63,5	107	16	35	193	38
6.4.50.7	4x500	60,8	40,0	28,7	25630	64,7	134	16	42	339	47
6.5.45.7	5x450	60,1	39,8	28,8	26040	64,2	134	16	42	229	47
6.6.45.7	6x450	73,9	48,6	34,7	31246	64,7	161	16	42	279	56

* = Sound pressure indication (LpA) at 3 m distance each air cooler (+/- 2 dB(A)) , free field conditions, according EN13487

Goedhart FC38Sp(dx) - R404A

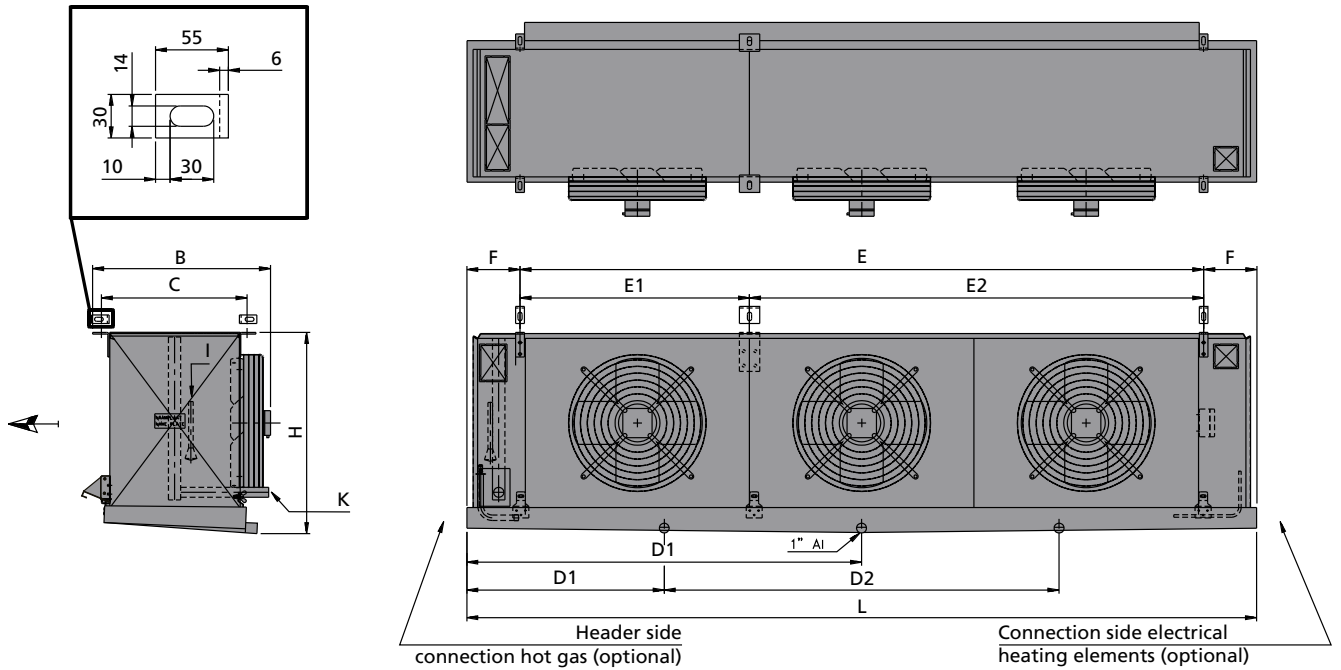

Declarations

Connection ≤ 35 mm	: Declaration of incorporation (SEP)
Connection 42mm and 54 mm	: module A
Group of fluid	: 2
PS	: 28 bar
TS	: +55 / -40 °C

Type	Dimensions										Electrical defrost at 3x400V-50Hz				Standard kW	Light kW**	
	L	B	H	C	E	E1	E2	F	D1	D2	Coil block		Drip tray				
	mm	mm	mm	mm	mm	mm	mm	mm	mm	mm	number	O [mm]	number	O [mm]			
FC38S																	
4.1.25.*	690	510	395	400	406			142	345		2x L=1000	66	1x L=1600	200	1,4		
4.1.30.*	765	510	470	400	481			142	383		2x L=1300	66	1x L=1600	200	1,6		
6.1.30.*	765	510	470	400	481			142	383		2x L=1300	66	1x L=1600	200	1,6		
6.1.35.*	970	640	550	500	606			182	485		3x L=1600	132	1x L=2200	300	2,8		
6.1.40.*	1070	640	625	500	706			182	535		3x L=1900	132	1x L=2500	300	3,3		
6.1.45.*	1170	640	700	500	806			182	585		5x L=1900	132	1x L=2500	300	4,8	3,7	
4.2.30.*	1210	510	470	400	926			142	605		2x L=2200	66	1x L=2500	200	2,8		
6.2.30.*	1210	510	470	400	926			142	605		2x L=2200	66	1x L=2500	200	2,8		
6.2.35.*	1540	640	550	500	1176			182	770		3x L=2800	132	1x L=3100	300	4,8		
6.2.40.*	1740	640	625	500	1376			182	870		3x L=3100	132	1x L=3700	300	5,4		
6.2.45.*	1940	640	700	500	1576			182	970		5x L=3700	132	1x L=4000	300	9,4	7,1	
6.2.50.*	2040	830	850	600	1576			232	1020		5x L=3700	132	1x L=4300	400	9,6	7,2	
6.3.30.*	1655	510	470	400	1371			142	828		2x L=3100	66	1x L=3700	200	4,1		
6.3.35.*	2110	640	550	500	1746			182	1055		3x L=4000	132	1x L=4600	300	6,1		
6.3.40.*	2410	640	625	500	2046			182	1205		3x L=4600	132	1x L=5200	300	8,0		
6.3.45.*	2710	640	700	500	2346			182	1355		5x L=5200	132	1x L=5800	300	13,5	10,2	
6.3.50.*	2810	830	850	600	2346			232	1405		5x L=5200	132	2x L=5800	400	13,5	10,2	
6.4.30.*	2100	510	470	400	1816			142	1050		2x L=4000	66	1x L=4600	200	5,3		
6.4.35.*	2680	640	550	500	2316			182	1340		3x L=5200	132	1x L=5800	300	9,1		
6.4.40.*	3080	640	625	500	2716			182	1540	1540	3x L=5800	132	1x L=6700	300	10,3		
6.4.45.*	3480	640	700	500		1558	1558	182	870	1740	5x L=6700	132	1x L=7300	300	17,6	13,4	
6.4.50.*	3580	830	850	600		1558	1558	232	895	1790	5x L=6700	132	1x L=7600	400	17,8	13,5	
6.5.45.*	4250	640	700	500		1558	2328	182	1063	2125	10x L=4300	-	2x L=4600	-	22,0	16,6	
6.6.45.*	5020	640	700	500		2328	2328	182	1255	2510	10x L=4900	-	2x L=5200	-	25,1	18,9	

Dimensions & Electrical defrost



Excellence

Passion

Integrity

Responsibility

GEA-versity

GEA Group is a global mechanical engineering company with multi-billion euro sales and operations in more than 50 countries. Founded in 1881 the company is one of the largest providers of innovative equipment and process technology. GEA Group is listed in the STOXX Europe 600 Index.



GEA Heat Exchangers

GEA Goedhart B.V.

Nijverheidsweg 6, 4695 RC Sint Maartensdijk
The Netherlands
Phone +31 (0)166 665 665, Fax+31 (0)166 663 698
www.goedhart.nl,
info.goedhart.nl@geagroup.com

GEA Heat Exchangers

GEA Goedhart s.r.o.

Kostomlátecká 180, 288 26 Nymburk
Czech Republic
Phone +420 325 519 951, Fax+420 325 519 952
www.goedhart.cz,
goedhart.cz@geagroup.com